

# FT 440 - Frying oil tester

## Spec-Sheet

VITO<sup>®</sup>  
oil filter system



### FT 440 frying oil tester - TPM & Temperature measurement

#### Functionality:

The FT 440 easily, quickly and reliably determines the quality of your oil. To do so, it measures the so-called „Total Polar Material“ (TPM) content in the oil and shows its value as an accurate percentage. The clear alarm via the coloured top alarm light makes it even easier to evaluate the quality of the oil. So you always know exactly when to change your oil. The FT 440 frying oil tester prevents the direct exposure of your hand to the hot oil.

To optimize the benefits of the FT 440 combine it with the VITO oil filter system.

#### All benefits at a glance:

- Measure the quality and temperature of your oil
- Change your oil at the right time
- Quick and reliable measuring results
- Supports HACCP quality standards
- Ergonomic and sturdy design
- High degree of protection (IP67)
- Clear alarms via on top alarm light using the traffic light principle



**VITO AG**

Tuttlingen, Germany

T: +49 7461 962890  
F: +49 7461 9628912  
info@vito.ag - www.vito.ag

# FT 440

## Frying oil tester

**VITO**  
oil filter system

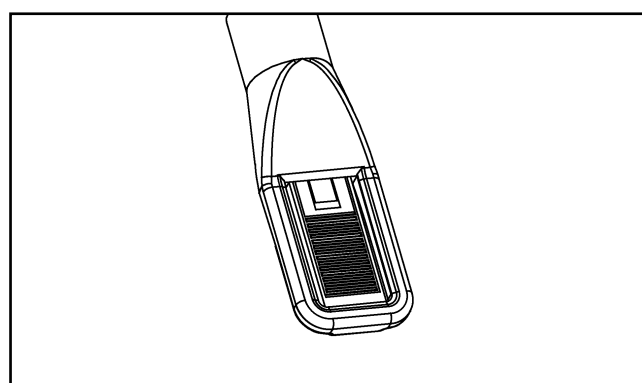
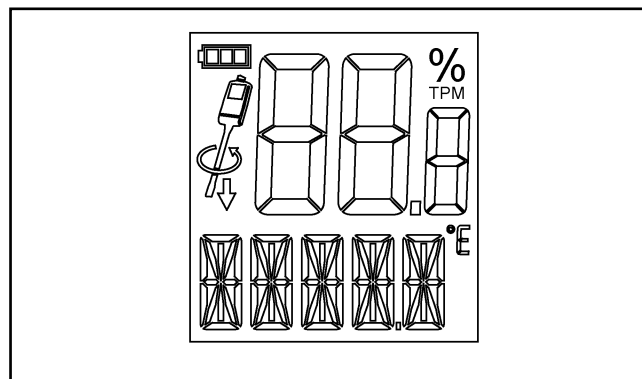
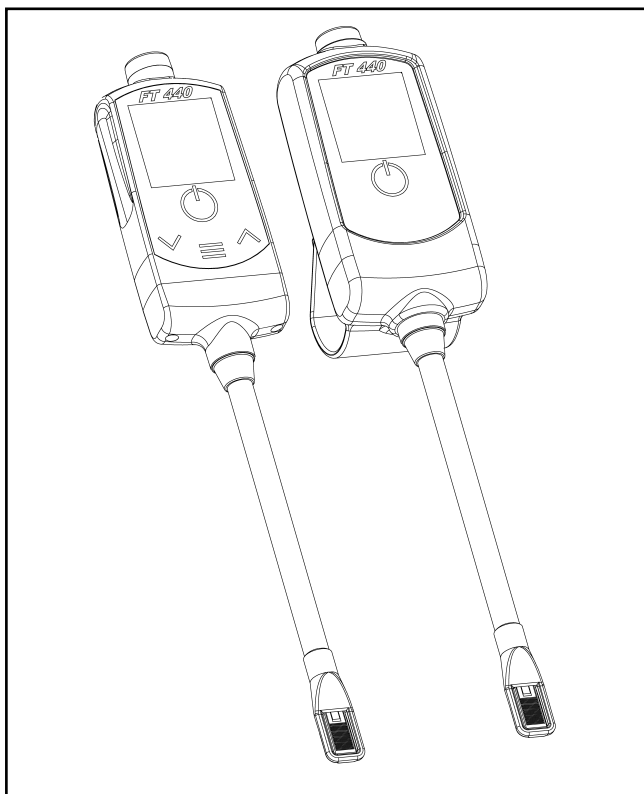

### FT 440 frying oil tester - TPM & Temperature measurement

#### Technical data:

|                    |  |
|--------------------|--|
| Measuring range    | +50 °C...200 °C 0%...40% TPM<br>+122 °F...392 °F |
| Accuracy           | ± 1 °C / °F ± 2 % TPM                            |
| Resolution         | 1 °C / °F 0,5 % TPM                              |
| Measured variables | temperature,<br>TPM (total polar materials)      |
| IP Rating          | IP 67<br>(high degree of protection)             |
| Battery            | 3 V Lithium (CR 2477)                            |
| Battery lifetime   | up to 3 years                                    |
| Dimensions         | 304 x 54 x 22 mm<br>11,9 x 2,1 x 0,9 inch        |
| Weight             | approx. 200 g<br>approx. 0,44 lbs                |
| Certificate        | Factory calibration certificate                  |



**VITO AG**  
Tuttlingen, Germany

T: +49 7461 962890  
F: +49 7461 9628912  
info@vito.ag - www.vito.ag